

USER MANUAL

BLIMO

TRAVEL PREMIUM

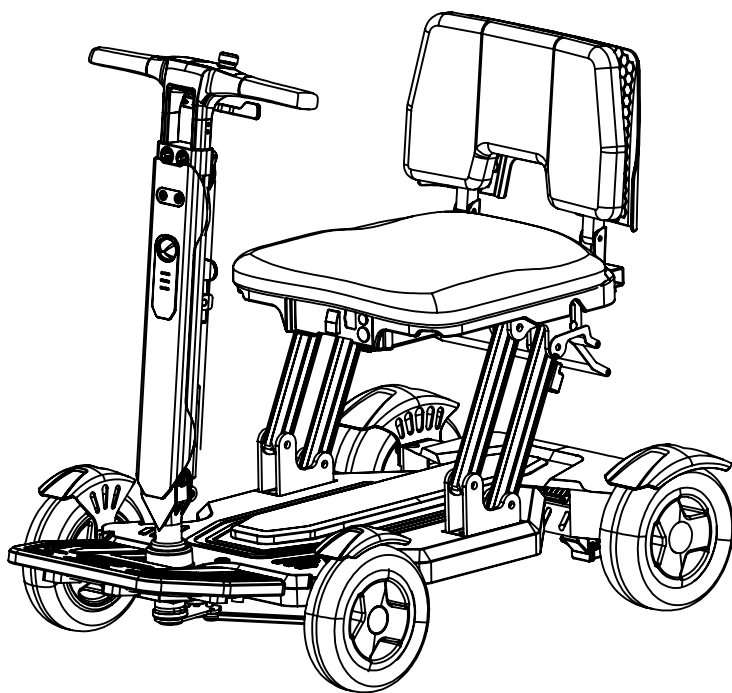

★ Before using the mobility scooter, please read this user manual carefully and save it for reference.

Introduction

Dear mobility scooter user :

Thank you for purchasing our intelligent mobility scooter for the elderly!

Before using the mobility scooter, please make sure to read this user manual carefully. If you cannot fully understand the contents or need some assistance, please contact the dealer or our after-sales service department.

This user manual contains information on the operating methods, equipment descriptions, and simple troubleshooting for each part of the scooter.

The symbol "★" used in this manual indicates actions and behaviors that require special attention.

「 Warning 」 「 Attention 」 must be carefully read and obey.

This user manual includes a maintenance record and notes. Please keep it properly.

If you transfer ownership of this scooter to someone else, please make sure to provide them this manual.

With the changes in design, all information and pictures in this manual are based on the factory standards. If there are any changes, we will not inform everyone again. Please understand it, thank you for your supporting.

Finally, we believe that our mobility scooter will make your life more colorful.

Catalogue

Main component	1
Performance parameter	2
Operation instruction	3
★ Unpacking instruction	3
★ Armrest installation (Optional)	5
★ Power switch	6
★ Speed adjustment	6
★ Driving Control	6
Lights and horns	7
Brake lever	7
Folding method	7
Battery and charging methods	8
★ Battery considerations	8
★ Charging method	8
★ Charger	9
Controller driver and its connections	9
Basic overhaul and maintenance	9
Daily inspection	9
Maintenance	10
Common troubleshooting	10
Warranty description	12
Components and parts	12

Main component

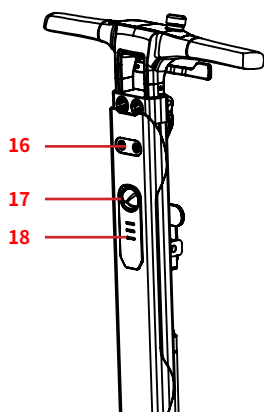
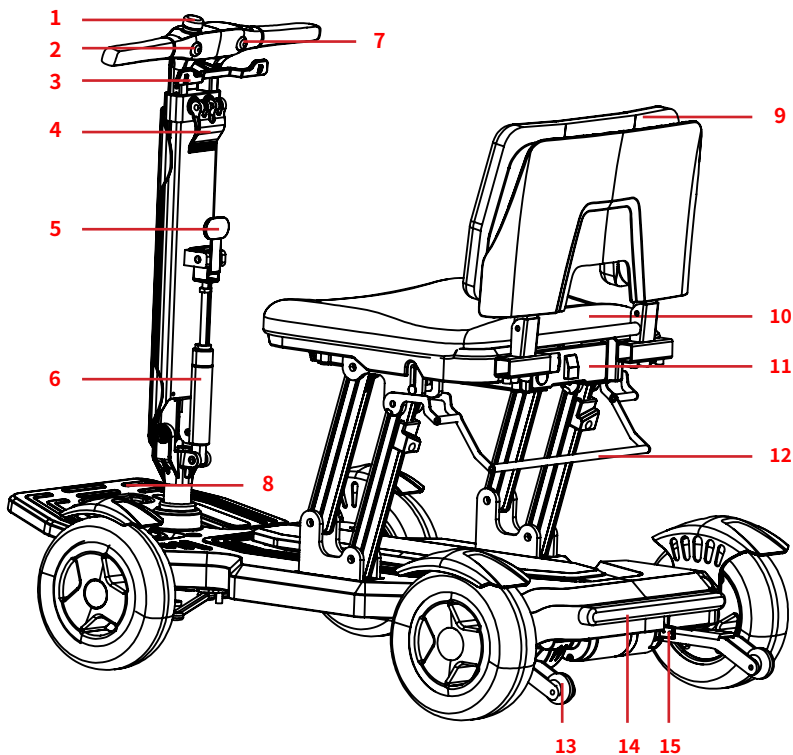

- | | | | |
|---|---------------------------------|----|---------------------------|
| 1 | Power switch & speed adjustment | 10 | Removable seat cushion |
| 2 | Head lamp switch | 11 | Battery |
| 3 | Throttle & Reverse | 12 | Seat lock operating lever |
| 4 | Height adjustment latch | 13 | Anti-tilt wheel |
| 5 | Front Angle adjustment switch | 14 | Taillight |
| 6 | Gas springs | 15 | Electromagnetic Brake |
| 7 | Horn switch | 16 | Front trim |
| 8 | Pedal | 17 | Headlamps |
| 9 | Backrest | 18 | Horn |

Performance parameter

Package size (L*W*H)	920*640*380mm
Unfold size (L*W*H)	1040*600*900mm
Fold Size (L*W*H)	1000*600*320mm
Seat cushion size (L*W*H)	400*400*40mm
Net weight	27KG(excluding armrests)
Gross Weight	29kg
Seat height from the ground	520mm
Handlebar height from the ground	800-850mm adjustable
Maximum load	120kg
Motor	250W brushless
Battery	Lithium battery 24V 5.8Ah * 2
Controller	Intelligent controller
Headlights	LED
Taillight	LED
Screen	LCD instrument
Rear wheel size	8 "PU solid tires
Front wheel size	8 "PU solid tires
Speed	0 ~ 6 km/h adjustable
Climbing Angle	≤12°
Steering	Rear wheel follow-up steering
Minimum turning radius	45cm
Obstacle crossing height	≤5cm
Travel distance	≤25km
Brake	Electromagnetic brake
Charger	Special DC24V/2A AC110-250V
Charging time	4-6h

Operation instruction

★ Unpacking instruction



- 1 Find the upward symbol “↑↑” on the outer packaging box and place the carton in the direction of the arrow. First, open the carton from the top and observe the position of the scooter’s wheels. Remove the outer carton and take out the scooter accessories, pedal accessories and excess sponge MATS. Observe whether there are bumps in the scooter and whether the accessories are complete.



Please ask your partner to assist with you if necessary, as wrong operation may lead to the damage the mobility scooter.



- 2 First pull down the knob at both ends of the pedal cross bar and turn it to the bump. Take out the pedal fittings and align them with the circular holes at both ends of the bar.
- 3 Insert the U-shaped pipe on the back of the foot pedal into the circular holes at both ends of the cross bar and restore the knob so that the top of the knob is stuck on the foot pedal. At the same time, the two ends of the "click" sound is heard, and the foot pedal is installed.

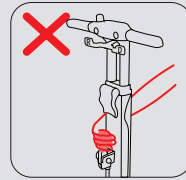
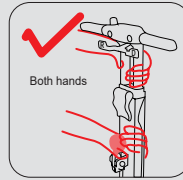

- 4** Press the red button with one hand and press the handle with the other hand, slowly lifting it to the appropriate angle.



Air pressure prop exist the a fixed risk, please make sure your both hands to operate it at the same time.



- 5** Remove the backrest. Hold the folding switch upward with one hand and hold the seat with the other hand. After you hear a click, release the folding switch and let it fall. At this point, the seat should remain level, and then put the seat cushion in place. Otherwise, repeat the above steps until the seat is level.



- 6** Open the handlebar height adjustment buckle, you can adjust the handlebar height up and down, and then lock the buckle. Finally, place the battery lock upward, place the battery in the battery carrier until it locks.

★ Armrest installation (Optional)

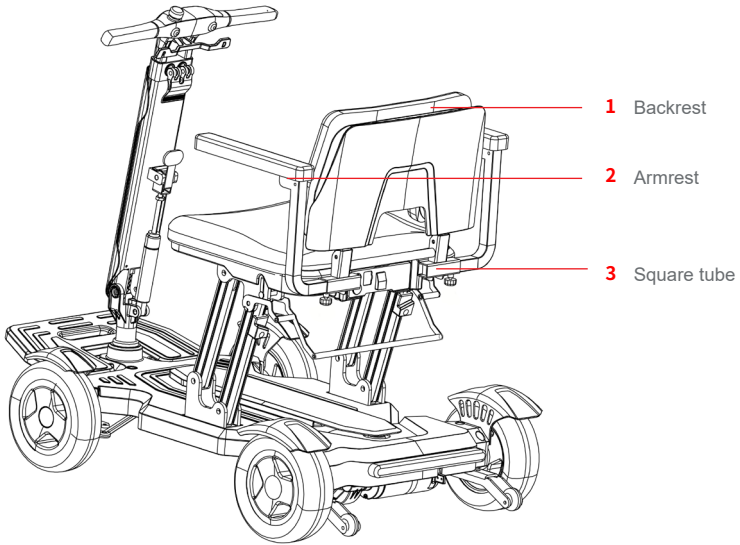

- 1 First open the knobs at both ends counterclockwise, and then insert the armrest into the square tube. Adjust the appropriate armrest position and tighten the knob clockwise to fix the armrest position.
- 2 Adjust the backrest by squeezing the backrest folding switch inwards.

★ Check the mobility scooter, instrument, footrest and battery .etc. for damage.
(if there is any damage, please contact the dealer for replacement)

★ Power switch

- 1 This scooter can be equipped with two pieces of batteries, the battery has a separate switch located at the front of each battery box, as shown in the figure, "○" indicates that the power off, "—" indicates that the power on.
- 2 Make sure that the battery power has turned on, rotate the round knob on the instrument clockwise until you hear a "click", then the screen will be lights up, now the mobility scooter has been turned on and you can drive.
- 3 Depending on your needs, you can use one battery separately or use two batteries at the same time.



Please do not turn off the power when the mobility scooter is driving, otherwise the electromagnetic brake will engage and the scooter will stop suddenly.

★ Speed adjustment

The speed can be adjusted the maximum forward speed within the range of 0.2Km/h ~ 6Km/h, which can be set arbitrarily. Rotate round knob counterclockwise for a slow speed setting, rotate the round knob clockwise for a fast speed setting.



★ Driving Control

- 1 The right thumb pushed forward the right joystick to go forward, and vice versa to go backward; The left thumb pushed forward the left joystick to step back, and vice versa to move forward.
- 2 After the speed adjustment rod is completely released, it will automatically stop in the "center" position, and the electromagnetic brake will automatically brake the vehicle.



Lights and horns

Pressing the yellow button will sound an alarm; Press the red button to turn on the headlight and press again to turn it off.



Brake lever

A red joystick under the taillight can switching between mobility driving and a manual drive.

"Mobility Drive": Make the brake lever down (Locked) for mobility walking.

"Manual drive": Make the brake lever up (unlocked) for hand push walking.



- Please turn off the scooter when you going to drive it when leave the mobility scooter.
- Do not operate the throttle with both hands at the same time.
- Do not turn off the power switch while driving, otherwise will lead to an emergency brake and drop risk.
- The braking distance will change according to the driving road conditions, so if you want to stop, please brake the mobility scooter in advance.

Folding method



Switch to manual drive mode.



Remove the seat cushion and backrest cushion and place them in the appropriate position.



Lift the folding lever with one hand and support the seat with the other hand, slowly lowering the seat.



Press the red button with one hand and the handlebar with the other hand to fully fold it.



Finally, the backrest is folded.

Battery and charging methods

★ Battery precautions

This product uses two sets of 24V 5.8AH high-performance lithium-ion batteries, which must be fully charged for the first use.

- 1 Power
- 2 Charging port
- 3 USB
- 4 Battery disassembly switch
- 5 Battery status



- Do not disassemble the lithium battery privately, otherwise it may cause accidents and body injury.
- Battery operating temperature: $5 \pm 2^{\circ}\text{C} \sim 40 \pm 2^{\circ}\text{C}$.
- Don't drive scooter on low battery capacity for a long time, otherwise the battery life will be shortened.
- Please charge the battery every two months, charge it about 80% of battery capacity. If the battery loses power for a long time, the battery will be damaged, and we will not bear the loss caused thereby.

★ Charging method



Switch to manual drive mode.



Direct to plug the charger plug into the charging socket of the battery under the seat.



Insert the charger power plug into the home power supply.



When the charging is connected to the home power supply, the red indicator lights up, and the charging time according to the battery state and temperature which is generally 2-6 hours.



After charging, the charger automatically stops working and the indicator changes to green, please pull out the input plug of the charger, and then pull out the plug of the battery side.

★ Charger

- 1 This product uses AC100-240V / DC24 / 2A lithium battery special charger, do not mix other chargers to avoid damage.
- 2 Do not disassemble or modify the charger.
- 3 Do not cover and block the charger to avoid affecting heat dissipation.
- 4 Keep the charging environment ventilated.

Controller driver and its connections

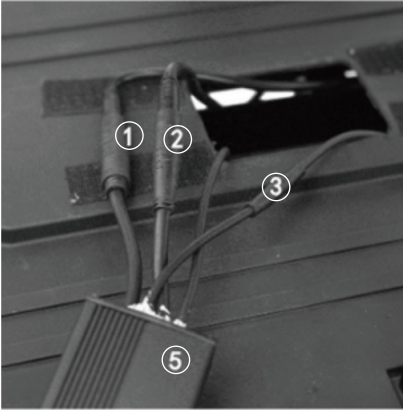

①

②

③

④

- 1 Controller connection to motor
- 2 Controller connection to battery
- 3 Controller connection to rear LED light
- 4 Controller connection to operation panel and front LED light
- 5 Controller unit

Basic overhaul and maintenance

★ Daily Inspection

Inspection item	Scope of examination
Handle	Is there a loose, whether it can be normal around?
	Is the expansion normal?
Seat and backrest	Is there any loose, inclined, and whether it can fold normally?
Speed adjustment knob	Does it rotate normally?
	Can you adjust the speed normally?
Forward and backward control lever	Can you push it down and return to the middle and stop?
Brake lever	Normal separation?
Battery status	Is the pointer meter leaking? Is the battery charge sufficient?

★ Maintenance

- 1 Check regularly insulation of all wires and tightening of wire end regularly.
- 2 Avoid moisture of all electronic control module, otherwise it must be completely dry before use.
- 3 Please use a soft duster cloth to wipe the dirt of the mobility scooter body and do not cleaning the scooter body with water.

Common troubleshooting

The controller contains a program to identify problems and troubleshoot. When the diagnostic program detects problems and errors, the LED on the control panel shines, the fault alarm buzzer will alarm, and the fault display LED shines continuously in the form of a 1-bit fault indicator code until troubleshooting. If the problem persists, please get in touch with us or the agent.

Fault code	Fault description	Failure category	Trouble shooting
E0.1	Over current fault	Drive failure	a) Check whether the instrument line sequence is correct b) Is the fault of the replacement instrument normal c) Is it normal to replace the controller d) Replace the instrument and controller at the same time
E0.2	Under voltage fault	Drive failure	a) Check battery power and charge b) Troubleshooting replacement of drive

Fault code	Fault description	Failure category	Trouble shooting
E0.3	Over voltage fault	Drive failure	a) Check battery power b) Troubleshooting replacement drive
E0.4	Stalled rotor fault	Drive failure	a) Check whether the motor is stuck b) Troubleshooting replacement of drive c) Troubleshooting replacement of motor
E0.5	The above mos fault	Drive failure	a) Troubleshooting replacement of driver b) Check the motor replacement
E0.6	The following mos fault	Drive failure	a) Troubleshooting replacement of driver b) Check the motor replacement
E0.7	Hall failure	Drive failure	a) Check whether the motor wiring harness is damaged, disconnected or short-circuited b) Troubleshooting replacement of drive c) Check the replacement motor
E0.8	mos over temperature fault	Drive failure	a) Cool down the drive b) Troubleshooting replacement of drive c) Check the replacement motor
E1.2	communication fail	Instrument/ drive failure	a) Check whether the instrument line sequence is correct b) Is the fault of the replacement instrument normal? c) Is it normal to replace the controller? d) Replace the instrument and controller at the same time
E1.7	Brake failure	Drive failure	a) Check whether the motor brake is closed b) Check whether the motor wiring harness is damaged or short-circuited c) Troubleshooting replacement of drive d) Check the motor replacement
E2.1	Forward and backward potentiometer falls off	Instrument failure	a) Check whether the handle is well connected b) Check whether the handlebar line sequence is correct
E2.2	The forward and backward potentiometers are not in the neutral position when turned on	Instrument failure	a) Check whether the handlebar is in the neutral position b) Check whether the handlebar line sequence is correct

Warranty description

Warranty project	Free warranty period
Main frame of mobility scooter	2 years
Motor	1 years
Battery	1 years
Controller	1 years

★ The following conditions are not covered by the warranty

- 1 Due to improper use, man-made damage, overload, unauthorized modification or privately dismantling the motor.
- 2 The battery is not properly charged, the battery is disassembled and modified, and not charged for a long time (2 months or more).
- 3 Consumables are not within the scope of warranty, consumables mainly refer to tires, bearings, etc.
- 4 Typhoon, flood, earthquake and other irresistible causes.

Components and parts

Name	Quantity	Remarks
Charger	1	/
Instructions	1	/
Wrench tools	3	/
Armrest	1	Additional selection is required
Basket	1	Additional selection is required

